

1275511

DRAWINGS ATTACHED

- (21) Application No. 5404/70 (22) Filed 4 Feb. 1970
- (31) Convention Application No. 685 (32) Filed 7 Feb. 1969 in
- (33) Denmark (DK)
- (45) Complete Specification published 24 May 1972
- (51) International Classification E06B 3/54//3/20
- (52) Index at acceptance

E1R 32
E1J 212 213 227 235 238 241 243



(54) IMPROVEMENTS IN AND RELATING TO WINDOWS

(71) I, BENT JENSEN JEPPESEN, of No. 3, Muldebærvej, Sejs, pr 8600 Silkeborg, Denmark, a subject of the King of Denmark, do hereby declare the invention, for which I pray that a patent may be granted to me, and the method by which it is to be performed, to be particularly described in and by the following statement:—

This invention relates to windows.

Windows are known which consist of pieces of coloured glass that are mounted in strips of lead which, at the corner and crossing points of the framework are assembled by soldering. This manufacturing technique is complicated and the production price is correspondingly high. From the Danish patent specification No. 85,739, a similar method is known, except that the strips of lead are replaced by thermoplastic H-strips. At the spots where two or more of these H-strips are to form a corner or crossing point, the strips are assembled by direct welding, in that the end of one strip is that much reduced in thickness that it is able to fit into the groove of the other strip. Subsequent to the welding, the surfaces of the strips are smoothed by applying additional molten plastic, and the surface layer is finally covered with a layer of solder which melts at a low temperature, to obtain the same appearance as the soldering compounds used in the traditionally produced windows having groove strips of lead.

Windows of the kind dealt with are being used more and more as decorative window panes, which are fitted on the inside of existing windows and consequently have to be adapted to their dimensions and, as far as their pattern and play of colours are concerned, should be matched with the surroundings. Especially for the latter reason it may often be desirable to make changes in an existing window; however, with the known windows this is almost impossible and calls at any case for a laborious job of work by skilled workmen.

It is an object of the invention to provide a window which it is possible to assemble, without any special professional

skill, from a do-it-yourself-kit and, if so desired, may be separated again in order to be reassembled in a modified form. 50

The invention thus relates to a window comprising a plurality of preferably polygonal pieces of glass or similar sheet material lying in the same plane, a and framework of strips that are connected with each other and which have grooves for receiving the edge parts of the glass or the like pieces and which, at their ends, are connected with each other via junction pieces having two, three or more branches and are provided with grooves in line with the grooves of the strips. According to the invention, this window is characterized in that the glass or the like pieces have integral edge ridges for releasable locking engagement with complementary recesses in the grooves of the strips. 55

Both the strips and the assembly pieces may expediently be of plastics of a suitable quality and colour and the glass-like pieces held in the framework may be made of plastics, which can be less vulnerable to jolts and blows than ordinary window glass and is more easily designed or shaped according to wish. The assembly pieces are expediently manufactured by casting, while the strips preferably are produced by extrusion. 60

By the assembling of the parts, the engagement between the edge ridges of the glass or the like pieces and the corresponding recesses in the grooves of the strips stabilizes the window; it is possible, however, to eventually increase the stability further by a few glueing or screw connections which may be of such nature that they do not prevent an easy separation of the parts. The said recesses will not complicate the manufacture of the H-strips, and when these strips possess such a resilience that their grooves can be opened sufficiently to allow the edge ridges of the pieces of glass or similar sheet material to pass, the locking mechanism constituted by these edge ridges and the complementary recesses will not impede the assembling of the window in the easiest way, viz. by simply pressing the H-strips onto the edge portions 65

70

75

80

85

90

95

of the glass or the like pieces. There exists another possibility however, of an H-strip being assembled with an edge portion of a plate by displacement in its longitudinal direction.

In order to augment the locking effect, the edge ridges of the glass or the like pieces and the corresponding recesses of the strips may have a barb-shaped cross section.

The invention will now be more fully explained with reference to the accompanying drawings, in which

Fig. 1 is a plan view, partly exploded, of a part of the window, and

Fig. 2 a section on a larger scale on the line II—II in Fig. 1.

The parts of the window shown comprises a rectangular piece 1 of glass or of plastics resembling glass, as well as four H-strips 2 and four junction pieces, viz. a cross piece 3, two T-shaped junction pieces 4 and a corner piece 5.

The strips 2 may be extruded of suitable plastics material and be cut into lengths according to the size of the piece of glass or similar sheet material 1. As shown in Fig. 2, the strips 2 have a central through hole 6 for receiving pins 7, Fig. 1, on each branch of the associated junction pieces 3, 4 or 5.

These junction pieces have simple grooves, in which the corner parts of the piece 1 of glass or similar sheet material are received and the H-strips 2 have analogous grooves 8 which, however, as shown in Fig. 2, have a lateral recess 9 at the bottom which, in the assembled window, is in locking engagement with an edge ridge 10 on the piece of glass or similar sheet material 1.

The said edge ridge does not, as indicated in Fig. 2, have to be continuous, but may consist of separate lengths, and it may be removed at the corners of the piece 1 of glass or similar sheet material, so that the junction pieces 3, 4 and 5 will not have to be

constructed with recesses 9 in their grooves.

It will easily be understood that the pieces 1 of glass or similar sheet material forming part of the window, do not need to be rectangular as shown in the drawing, but may have any other, through preferably polygonal shape. Accordingly, junction pieces having various shapes may be employed, e.g. shaped principally like a Y, X or K, with angles corresponding to the corner angles of the pieces of glass or similar sheet material.

WHAT I CLAIM IS:—

1. A window comprising a plurality of preferably polygonal pieces of glass or similar sheet material lying in the same plane and a framework of strips that are connected with each other and which have grooves for receiving the edge parts of the glass or the like pieces and which, at their ends, are connected with each other via junction pieces having two, three or more branches and are provided with grooves in line with the grooves of the strips, characterized in that the glass or the like pieces have integral edge ridges for releasable locking engagement with complementary recesses in the grooves of the strips.

2. A window as claimed in claim 1, characterized in that the strips possess such a resilience that it is possible for their grooves to be opened sufficiently in order to allow the edge ridges of the glass or the like pieces to pass through the grooves and into said recesses.

3. A window, substantially as described with reference to the drawings.

MATHYS & SQUIRE,
Chartered Patent Agents,
10, Fleet Street,
London, E.C.4.
Agents for the Applicant.

FIG.1

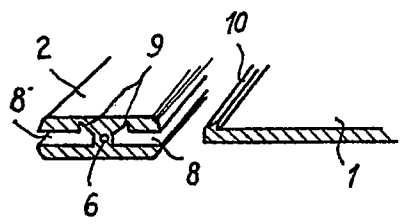
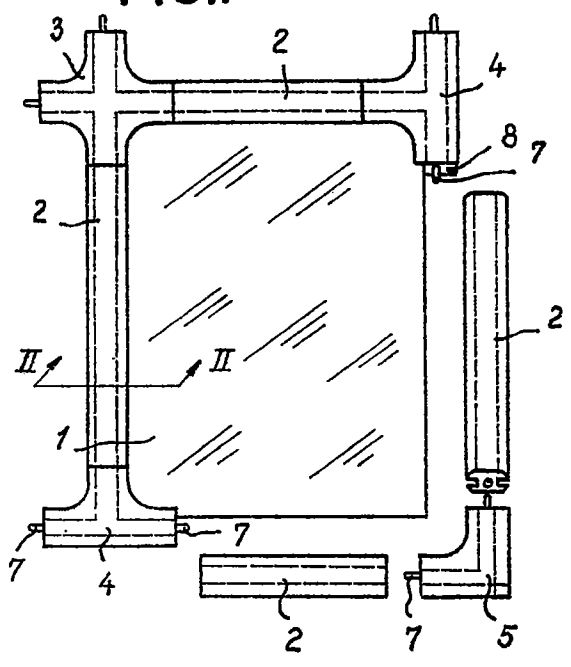

FIG.2